

角柱や円柱の体積

次の図形の体積を求めましょう。

①

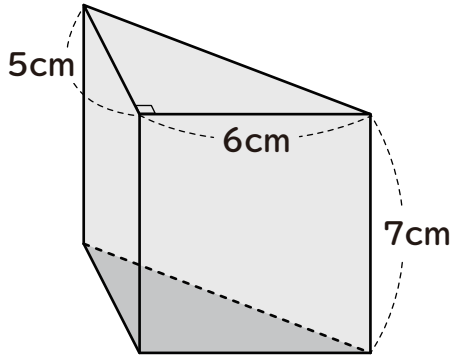

②

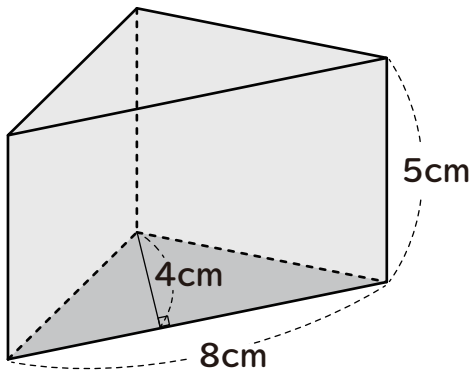

③

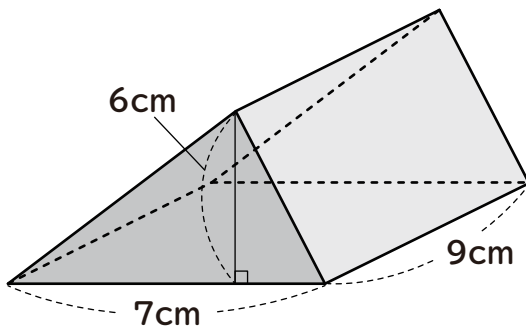

角柱や円柱の体積

次の図形の体積を求めましょう。

①

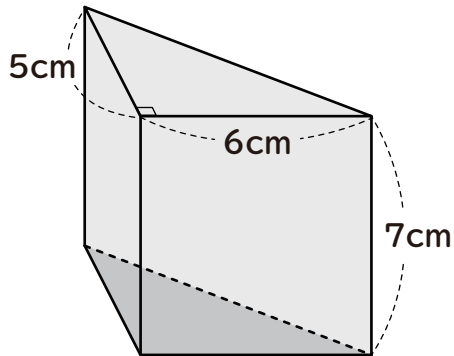

$$6 \times 5 \div 2 \times 7 = 105$$

$$\underline{105 \text{ cm}^3}$$

②

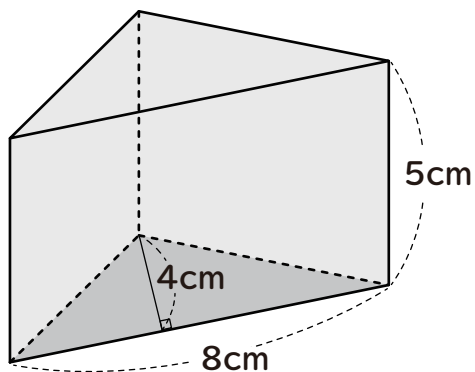

$$8 \times 4 \div 2 \times 5 = 80$$

$$\underline{80 \text{ cm}^3}$$

③

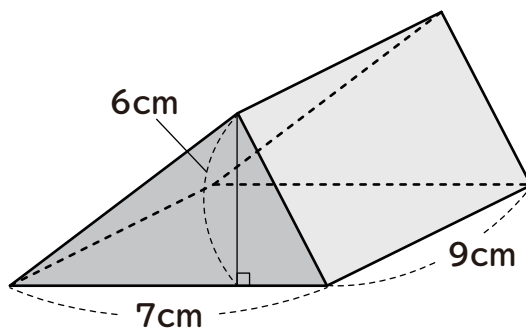

$$7 \times 6 \div 2 \times 9 = 189$$

$$\underline{189 \text{ cm}^3}$$